



# Pressure Vessel and Heat Exchanger Manufacturers Increase Efficiency Using Innovative Software

AutoPIPE<sup>®</sup> Vessel Produces Detailed Drawing Deliverables to Improve Competitiveness and Design Quality

## STRIVING FOR EFFICIENCY

World leaders in pressure vessel and heat exchanger manufacturing need to cater to huge production requirements. Hence, they need to speed up the modeling and drawing process, as well as the calculation and cost estimation time for their plant vessels, while staying in compliance with international design standards and codes. Additionally, they are required to reduce bidding time for proposals generated for their clients.

To achieve this, vessel producers need a solution that helps them increase design efficiency, save engineering hours, and ensure confidence in vessel design while improving competitiveness through improved design quality.

## MAXIMIZING PRODUCTIVITY

Many of these producers choose Bentley's AutoPIPE Vessel, a vessel design and analysis application, for their projects. They choose AutoPIPE Vessel for its reliability, speed, ease of use, optimization and calculation capabilities, and the ability to produce detailed drawing deliverables.

The application's processing speed enables the design team to analyze more complex models in less

time. Automated detailed drawings reduce manual drawing time and rework and deliver accurate and safe designs using fewer resource hours.

AutoPIPE Vessel provides the most productive, cost-effective, and accurate designs for the safe operation of vessels under all loading conditions. The software supports numerous regional and global standards including pressure vessel design codes and regional wind, seismic, wave, and blast loading codes.

By enabling the use of new and older design codes, and material standards from any year, AutoPIPE Vessel improves flexibility for re-rating and revamping of existing vessels. This helps shorten design time and rework by eliminating guesswork, and reduces training time by providing a single, easy-to-use application for global projects.

## ACCELERATING DESIGN TIME

Comprehensive, flexible modeling, in-built templates, and an easy-to-use interface enables the designers to find solutions quickly, improves the efficiency of modeling, and increases profitability. AutoPIPE Vessel helps users perform mechanical design of tall distillation columns (towers) much faster. Teams are able to improve productivity and delivery time by enabling easier, more accurate design and analysis.

"We switched to AutoPIPE Vessel so that we could quickly and easily create 3D models and design almost any kind of pressure equipment and heat exchanger, including complex types not completely matching a TEMA Type. In addition to being user friendly, AutoPIPE Vessel automatically calculates and optimizes thicknesses, updates the 3D model in real time to check clashes or erroneous data, and when the output report is generated, it's easy to understand!"

– Cristian Peri, Technip, Rome

## SUMMARY INDUSTRY

Vessel manufacturing, industrial gas, petrochemical, and oil and gas

## AREA OF OPERATION

Pressure vessels, heat exchangers, tanks, and air coolers

## OBJECTIVE

Simplify vessel stress analysis and achieve optimized and compliant designs in the least amount of time.

## PROJECT PLAYBOOK

AutoPIPE<sup>®</sup>

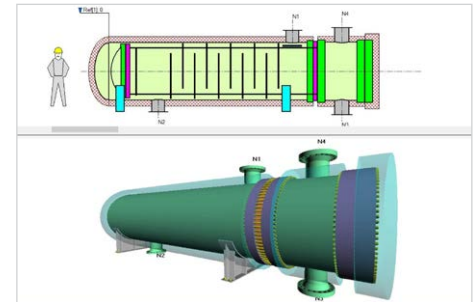

Heat exchanger model in AutoPIPE Vessel.

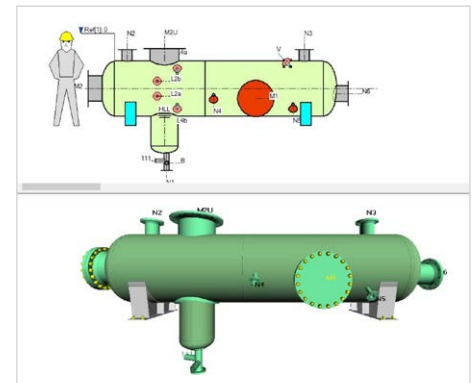

Pressure vessel model in AutoPIPE Vessel.